

Backflush filter

R5-8

Variable segment cleaning with internal medium, rated pressure up to 16 bar (232 psi)

Connection sizes: DN 32 to DN 200, cast design

1. Features

Powerful, fully automatic filtration

- Used in shipping and industry
- Continuous filtration supports rational production processes
- Low backflush flow rates and optimal cleaning of the filter element improve filtration efficiency
- Backflush nozzle positioned directly on the filter element guarantees maximum cleaning effectiveness
- Perfect synthesis of ecology and economy
- Mature engineering and robust design
- Compact design
- Filter ratings from 25 to 1000 µm absolute
- Easy to service
- Worldwide network of distribution and service agents



2. Operating principle

- The medium being filtered flows via the inlet tube (1) into the filter housing and into the filter insert, which is open at the bottom (2). The medium passes through the filter element from the inside to the outside. During this process, contaminants are trapped on the inner side of the wire cloth.
- The filter housing contains a filter element with pleated wire cloth through which the medium flows and contaminants are trapped (2).
- When a defined differential pressure is reached or after a settable time interval, the fully automatic backflush process starts. In order for the backflushing process to be efficient, there must be operating overpressure on the outlet side (clean side) of the filter.
- When the backflush start time is reached the flush valve opens (5) and the gear motor (4) starts to turn the flushing nozzle (6), which is located in the filter element. Thereby the whole filter surface (2) bypasses the flushing nozzle.
- The process medium that has already been filtered flows at high speed in the opposite direction through the vertical slot (7), which is located directly on the filter element. The trapped contaminants (7) are discharged from the system via the flush pipe.
- The flush valve closes again when the filter element has been turned approximately 400°, so that the backflush process is completed in only a few seconds.
- Since the element is turned, only the part covered by the cleaning nozzle is actually cleaned; the remainder can continue to be used for filtration → operation is not interrupted.

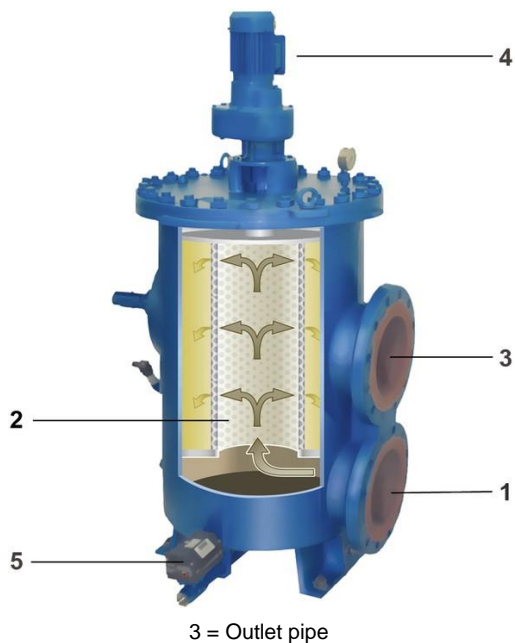

3. Technical Data

Connection:	DN 32 to DN 200
Flange:	DIN 2501 PN 16
Material:	Nodular cast iron 40/0.7040
Max. operating pressure:	16 bar
Test overpressure:	32 bar
Max. operating temperature:	180 °C
Filter element:	Screen basket with pleated wire cloth
Filter rating:	25 to 1000 µm absolute

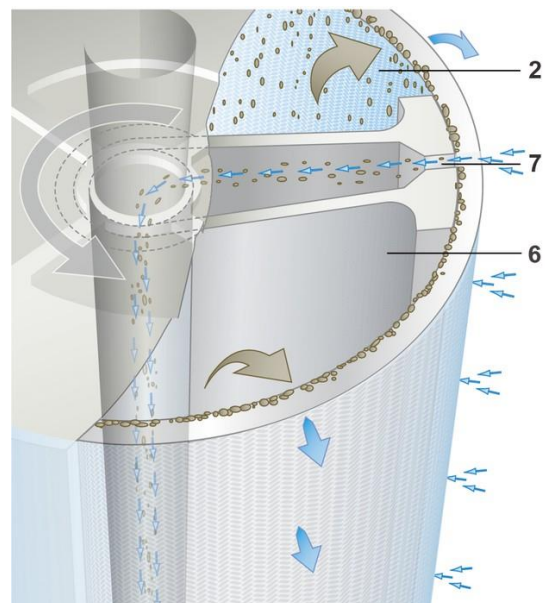

4. Dimensions

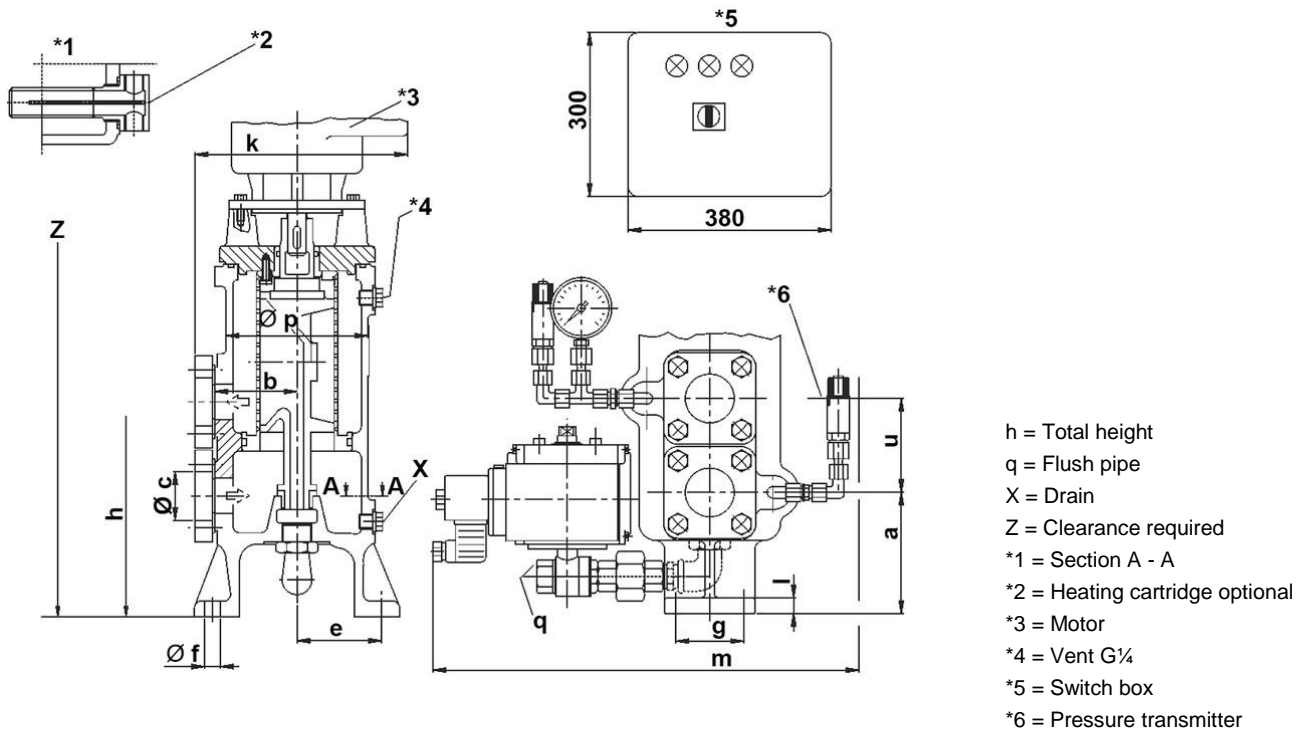

All dimensions except "q" and "X" in mm.

Type	DN	a	b	$\varnothing c$	e	$\varnothing f$	g	h	k	l	m	$\varnothing p$	q	u	X	Z	Capacity [l]	Weight [kg]
RA05W110F02	32	108	73	43	75.0	14	50	740	190	14	378	126	G $\frac{1}{2}$	84	G $\frac{1}{4}$	660	2.1	39
RA06W110F03	40	113	120	49	75.0	14	90	810	285	13	410	176	G $\frac{1}{2}$	115	G $\frac{1}{4}$	750	5.5	54
RA07W110F03	50	113	120	61	75.0	14	90	810	285	13	410	176	G $\frac{1}{2}$	115	G $\frac{1}{4}$	750	5.5	54
RR08W110F05	65	130	160	77	123.5	14	100	938	350	12	550	270	G $\frac{1}{2}$	190	G $\frac{1}{2}$	900	19.0	97
RR09W110F05	80	130	160	90	123.5	14	100	938	350	12	550	270	G $\frac{1}{2}$	190	G $\frac{1}{2}$	900	19.0	97

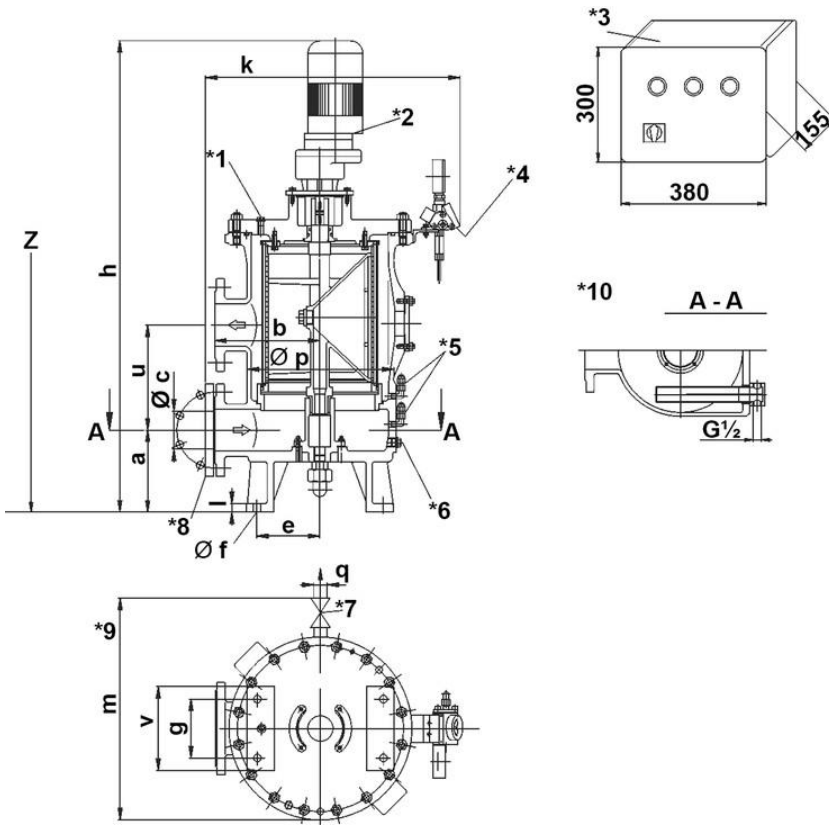

- Z = Clearance required
- *1 = Vent G $\frac{3}{4}$
- *2 = Motor
- *3 = Switch box
- *4 = Differential pressure indicator optional
- *5 = Pressure transmitter
- *6 = Drain G $\frac{1}{2}$
- *7 = Flush pipe
- *8 = Reducing mating flange
- *9 = Graph without motor
- *10 = Heating cartridge

All dimensions except "q" in mm.

Type	DN	a	b	Ø c	e	Ø f	g	h	k	l	m	Ø p	q	u	v	Z	Capacity [l]	Weight [kg]
RR093110F07	80*	195	250	90	150	18	140	1125	650	20	560	346	G $\frac{3}{4}$	250	200	1180	45.0	205
RR103110F07	100	195	250	100	150	18	140	1125	650	20	560	346	G $\frac{3}{4}$	250	200	1180	45.0	205
RR113110F46	125	236	280	125	175	23	200	1300	760	20	650	400	G1	270	260	1600	80.0	250
RR113110F09	125*	276	350	141	225	23	200	1421	820	20	740	516	G1	350	280	1680	154.0	495
RR123110F09	150*	276	350	169	225	23	200	1421	820	20	740	516	G1	350	280	1680	154.0	495
RR143110F09	200	276	350	200	225	23	200	1421	820	20	740	516	G1	350	280	1680	154.0	495

* Reducing mating flanges (DN 100, DN 125, and DN 200) to DIN 2501 PN 16 for DN 80 and DN 150 connections.

5. Design and application

The design of the backflush filters is based on the respective customer's requirements. The material, type of construction and filter surface and rating are expertly adapted to the specific filtration task based on the medium and capacity.

The task can be optimised with the freely variable options available for the backflush filters.

Options:

- **Heater**
Capacity and size optimally matched to filter sizes.
Steam and electric versions available.
- **Magnetic elements**
Strong permanent magnets can be used.
- **Control**
Control by means of a switch box with a programmable automation module.
Easy parameterising with buttons and display.
Programming and simulation on a PC.
- **Pressure transmitter**
Differential pressure monitored with a pressure transmitter.
This permits precise monitoring of the differential pressure using the PLC module in the switch box.
Max. temperature: 150 °C
Max. operating pressure: 40 bar
Measuring tolerance: 0.3 %
- **Bypass filter**
Manual, semi-automatic, fully automatic with change-over unit (manual, fully automatic).
- **Step nozzle**
To reduce flush volume.

Backflush filters are not at all complicated to use and they guarantee continuous filtration. The necessary steps are described in the following:

- The filter comprises a bowl with a cover and a gear motor.
- The bowl contains a vent port, a drain port and a filter element.
- The filter must be filled and vented before it is put into service. It must not be operated with the full pump flow when empty.
- Switch on the filter controller and start a flushing process with the hand release. If the viscosity of the medium is very sensitive to temperature, the filter controller should not be switched on until the filter reaches its normal service temperature.
- The filter controller must be switched off if the plant is not in service.
- In order for the backflushing process to be efficient, there must be operating overpressure during the flushing process on the outlet side of the filter.
- Backflushing starts automatically after a defined time or when the maximum differential pressure is reached. If the differential pressure exceeds 3 bar, the filter must be removed from service or changed over to bypass. Then dismantle the filter and clean the wire cloth cylinder (refer to "Cleaning").
- When a flushing process is tripped, the gear motor is switched on and the flush valve for the flushing medium outlet opens. The medium flows from the clean side through the filter element and into the internal nozzle as the flushing nozzle is turned by the gear motor.
- The flushing medium flows through the wire cloth at high speed, so that the contaminants trapped in the filter are detached and discharged via the flushing outlet and the flush pipe connected to it.
- The filter controller is programmed so that the flush valve closes and the gear motor is switched off after approximately 1¼ turns of the flushing nozzle.
- To clean the filter, switch off the filter controller, dismantle the gear motor, loosen the cover fixing screws and remove the cover. The complete filter element can now be lifted vertically out of the filter. To clean the filter element manually, spray it with steam, compressed air or water from the outside towards the inside. Pre-treat the element with a suitable solvent if the dirt cannot be removed easily. It may be necessary to dismantle the pleated wire cloth cylinder.

6. Type number key

Type number key with selection example for R5-8 backflush filter DN 32 to DN 200

Main product group

R Automatic filter

Series

R Cast design

A For nominal diameters 32 - 50

Inlet and outlet connections

05 Flange DN 32

06 Flange DN 40

07 Flange DN 50

08 Flange DN 65

09 Flange DN 80

10 Flange DN 100

11 Flange DN 125

12 Flange DN 150

14 Flange DN 200

Filter connection standard + rated pressure

3 EN 1092 PN 16 bar

W Factory standard

Position of main connections

1 Above one another on the same side

Cover fastening

1 Stud bolts or hexagon screws

Options

0 Standard version

2 Electric cartridge heater

3 Steam/thermal cartridge heater

7 Version without non-ferrous metals

G Rubber coating

Type of inner assembly

F Inner assemblies for automatic filter with internal medium

Inner assembly size

XX

Housing version

B Coated

Nozzle material

4 Cast bronze

Number for special types or design features

XX

10 Nominal diameter 150/200

R R 10 3 1 1 G F 07 B 4 10